



GAMMA
TECHNOLOGIES

SPACE SYSTEMS SIMULATIONS

Propulsion, Thermal, Energy, and Life-Support
Systems Simulations

Multi-Physics, Model-Based System Simulation

GT-SUITE is the leading multi-physics CAE platform for component, subsystem, and system-level simulation across modern space applications. Developed by Gamma Technologies, GT-SUITE combines validated libraries for fluid flow, thermal systems, electrical systems, controls, chemistry, and mechanical physics in one integrated environment. This deep physics approach enables engineering teams to develop propulsion systems, cryogenic architectures, life-support systems, thermal networks, battery systems, and operational digital twins with confidence.

Our Expertise

- Propulsion Systems
- Cryogenic Systems
- Fuel Systems
- Environmental Control & Life Support
- Thermal Management
- Electric, Hybrid & Battery Systems
- Integrated Systems
- Fluid & Hydraulic Systems
- Multi-Body Mechanics



Environmental Control and Life Support Systems

Design integrated environmental and thermal control systems for spacecraft applications.

- Onboard Oxygen Generation Systems (OBOGS)
- Pressure swing adsorption
- Cabin airflow and thermal regulation
- Liquid cooling circuits
- Fluid network analysis

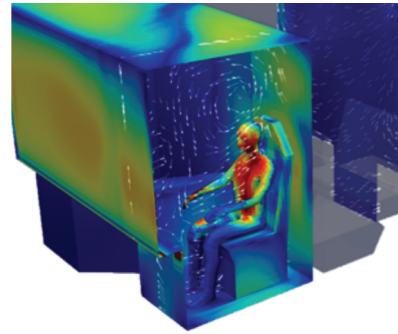

Cabin Airflow and Human Comfort Modeling

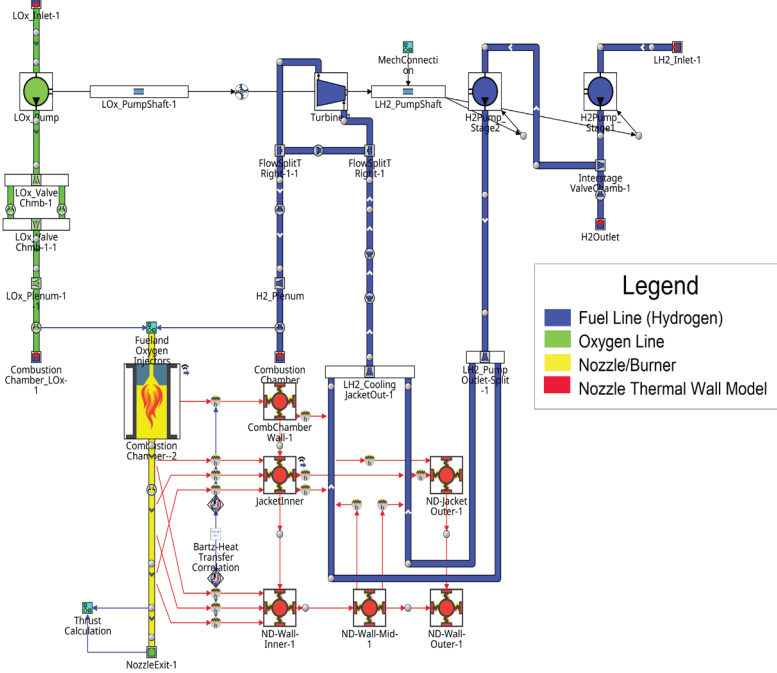

Rocket Engine simulation in GT-SUITE

Battery Systems and Energy Storage

Develop reliable energy storage systems for modern space platforms.

- Mission-specific aging prediction
- Battery electrochemistry simulation
- Thermal behavior analysis
- Charge/discharge performance
- State-of-health and life estimation

Propulsion, Fuel, and Power Systems

Develop integrated propulsion and onboard power architectures for modern space applications. Simulate rocket engines, thrusters, fuel systems, hybrid-electric configurations, and connected thermal and electrical networks within a unified physics-based environment.

- Fuel transport and pressurization
- Refueling and venting operations
- Combustion dynamics and chemistry
- Cryogenic flow and chilldown
- Water hammer and surge analysis
- Thermal and electrical integration
- Hybrid-electric propulsion systems
- Battery aging and thermal behavior
- Mission-cycle energy performance

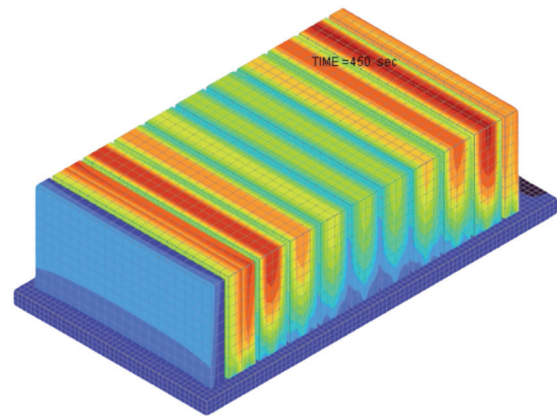

Advanced Battery Thermal Management Simulation in GT-SUITE

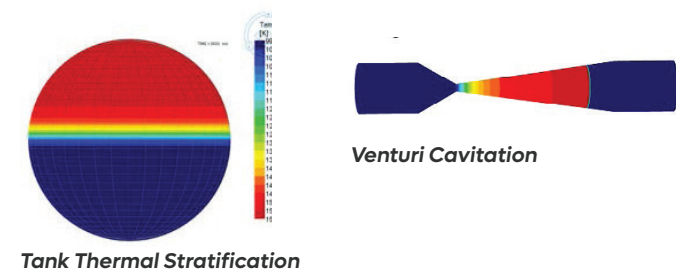

Cryogenic Systems

Simulate cryogenic system behavior under extreme operating conditions.

- Line chilldown and two-phase flow
- Thermal stratification and boil-off
- Helium pressurization systems
- Refueling operations
- Water hammer and transient surge analysis